

High speed folding Door

# Firstsystem



Complies with the standard

**EN 13241-1**

Agreement N° P05-047



**The folding door : for outside traffic**



Instant profitability for this simple and sturdy door that will accelerate your performance. The Record **Firstsystem** door seals your openings and provides you great thermal and phonic insulation at the same time. Fast and secure, the Firstsystem will never let you down.



[www.agta-record.com](http://www.agta-record.com)



**record**

High speed folding door  
**Firstsystem**



**A simple and sturdy door adapted to industrial constraints:**

- Industrial steel frame 25/10.
- Twin motor fail protection.
- Presence detection assured by a double row of safety cells.
- Twin speed motors– up speed  $1 \text{ m} \cdot \text{s}^{-1}$  – down speed  $0.49 \text{ m} \cdot \text{s}^{-1}$
- Industrial control panel with heavy duty PLC and contactors
- Door panel assembled by ultrasonic welding
- Prestressed polyester fabric  $670\text{g}/\text{m}^2$  laminated both sides with PVC.

**A wide range of colors and solutions to meet all your expectations :**

- 15 panel colors available as standard
- Vision portholes rows \*
- Many solutions for automatic or manual opening actuation
  - Push button, pullswitch, remote control...
  - Radars, photo cells, induction loop...
- Stainless steel structure \*
- Double skin door panel for improved thermal and phonic insulation \*
- 2 Opening heights for vehicles or pedestrian \*

**People and building safety :**

- Extra people safety :
  - Safety edge \*
  - Infrared detection\*, light barriers\*
  - Laser detection \*
- Product complies with standard EN 13241-1
  - EMC conformity
  - IP 65 Control panel
- Emergency openings :
  - Containment pin \*
  - Ratchet wrench \*
  - Automatic counterweight opening \*

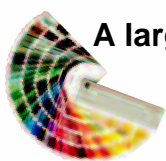

**A large choice of colors is available to integrate Firstsystem to your environment**

**Up to 6 m x 6 m !  
 Interior - Exterior**

- Self standing steel frame
- Twin motorization
- Wind load up to class 5

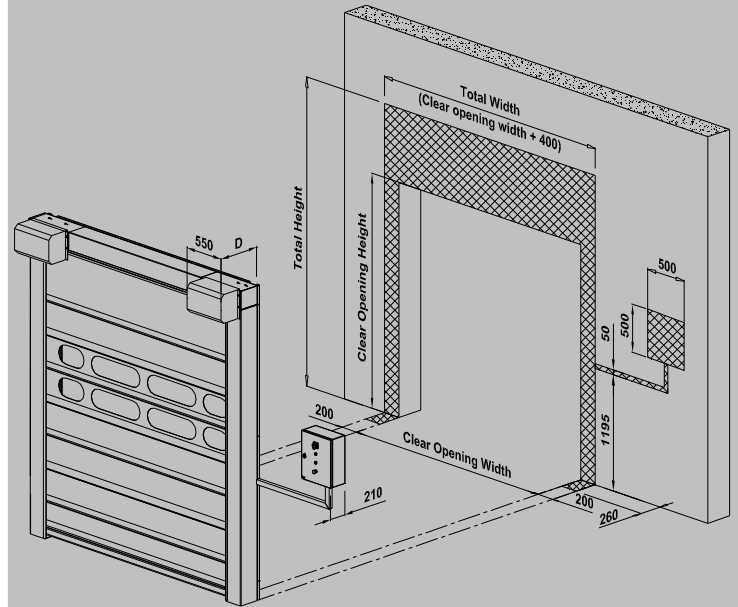

**Engine**

2 speed three-phase 380V  
 0,37/0,55 Kw up to 1,1/2,2 Kw  
 2 engines on front side

**Operating speed**

Opening  $1 \text{ m} \cdot \text{s}^{-1}$  - Shutting  $0,49 \text{ m} \cdot \text{s}^{-1}$

**Control panel**

Industrial control  
 Steel casing (w) 500 x (h) 500 x (d) 200  
 IP 65 protection class

**Wind load**



Class 4 or 5 (depending on dimensions)

\* Optional equipment

Production

 record industry SA – F38

[www.agta-record.com](http://www.agta-record.com)

